

Specification sheet

LF 190

FA 4X2 Rigid, 16t

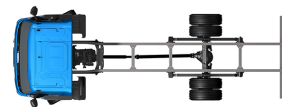

ENGINES

- LF 190 PX-5 (139 kW / 189 hp)
- LF 210 PX-5 (153 kW / 208 hp)
- LF 230 PX-7 (167 kW / 227 hp)
- LF 260 PX-7 (189 kW / 257 hp)
- LF 290 PX-7 (212 kW / 287 hp)

GVM¹⁾

16000 kg

Max. front 6000 kg

Max. rear 10500 kg

GCM²⁾

16000 kg

016F4602ABAA - 202345C - 18-08-2023

DAF Trucks Ltd, UK, Haddenham, HP17 8LJ, www.daf.co.uk

CAB EXTERIOR

Day Cab with steel bumper, tinted glass and electric window openers. Main mirrors and wide angle mirrors electrically heated. Cab width 2130 mm.; Green tinted glass; Electrically adjustable mirrors; Mirror brackets, body 2.50-2.60 m; Front view mirror.

Optional

02576 Extended Day Cab	07343 Kerb view window co-driver door
02106 Sleeper Cab	
03175 Cab suspension rubber and mechanical	00915 Side no glass / rear single glass
01605 Cab suspension mechanical reinforced	09101 Green tinted glass, heated
09983 Fog lights	09282 Mirror brackets, body 2.30-2.40 m
09984 Fog lights and cornering lights	09283 Mirror brackets, body 2.40-2.50 m

AERODYNAMICS

Optional

09287 Side collars prepared	07112 Side collars long (set)
------------------------------------	--------------------------------------

COLOURS

; Head lamp panel and bumper: Stone Grey; Chassis colour grey..

Optional

06150 Solid cab colour	04431 Special metallic cab colour
00061 Special solid cab colour	
06151 Cab metallic colour	06485 Head lamp panel and bumper: cab colour
	16153 Cab and chassis colours

CAB INTERIOR

Mechanically adjustable steering column; Driver seat: air suspended; Co-driver seat: fixed velour; Storage box on engine tunnel.

Optional

09271 Steering wheel, leather, colour black	00967 Seat belts red
03516 Pneumatically adjustable steering column	04346 Lower bunk, normal level
06012 Co-driver seat: fixed vinyl	02213 Air conditioning
03376 Dual mate seat, vinyl	03703 Auxiliary cab heater Air Top 2000
00072 Dual mate seat, velour	04246 Roof hatch, manual control
02600 Co-driver seat: air suspended	04258 Roof hatch, electric control
09106 Dual mate seat, luxury version	

COMMUNICATION AND DRIVING MANAGEMENT

FMS connector, prepared; Tachograph digital, Stoneridge 1C version G2V2; Adaptive Cruise Control with FCW and AEBS-3.

Optional

16155 Audio equipment, makes and types

SAFETY AND SECURITY

Lane Departure Warning System; Vehicle Stability Control (VSC); Basic engine immobiliser system.

Optional

08631 Air bag (driver) and 2 seat belt tensioners	06634 Immobiliser 5 minutes and alarm (SCM BV03-B2)
01725 Reverse warning	06635 Immobiliser 15 minutes and alarm (SCM BV03-B3)
07414 Reverse warning with self-adjusting volume	
06633 Immobiliser 5 minutes (SCM BV03-B1)	16156 EC-ADR packages

SUSPENSION AND AXLES

Front: 6.00 t, parabolic, F60; Rear: 10.50 t, parabolic, SR10.22.

Optional

00948 Rear axle SR10.26	01372 Rear springs air
--------------------------------	-------------------------------

WHEELS AND TYRES

Front axle(s): 285/70R19.5; Driven rear axle(s): 285/70R19.5; Wheel protection rings silvergrey.

Optional

06764 Wheel protection rings black	16152 Tyre makes and types
---	-----------------------------------

DRIVELINE

Engine PX-5, 4 cylinder diesel engine, 4.5 litres. Output 139 kW (189 hp) at 2300 rpm. Max. torque 745 Nm at 1200-1700 rpm.; Exhaust emission Euro 6; Engine idle shutdown, 5 minutes; Manual gearbox, 6 speeds; Gearbox ratio 6.58-0.78; Rear axle ratio 4.56.

Optional

04393 Manual gearbox, 9 speeds	09888 Automatic gearbox, 5 speeds
07667 Automatic gearbox PowerLine, 8-speed	02313 Gearbox direct drive

BRAKE SYSTEM

Exhaust brake.

CHASSIS

Wheelbase 4.50 m / rear overhang 2.45 m; Side member height 270 mm; EAS unit right, discharge right rearward; Plastic fuel tank 170 l; Tank for AdBlue® 30 l, right-hand side chassis; Spray suppression.

Optional

07071 Spare wheel carrier right-hand side	03323 Rear light with LEDs
--	-----------------------------------

DRAWBAR AND TRAILER EQUIPMENT

Closing member.

Optional

04661 D-value cross member D=8.5

BODIES AND PREPARATIONS FOR BODYING

No BodyBuilder Module (BBM); Application connector chassis; Standard body attachment hole pattern.

Optional

09952 BodyBuilder Module (BBM) full	01503 Side marker lights
02597 Application connector for tail lift control	07487 Body attachment BAM 1, loose consoles supply
02950 Application connector for hydraulic platform	07488 Body attachment BAM 3, loose consoles supply
09240 Application connector for refuse collector	

POWER TAKE-OFF (PTO)

Optional

06624 Indirect front engine PTO	01250 Front engine PTO with generator preparation 30 kW
00590 Front engine PTO with generator preparation 17 kW	16148 PTO types and positions
06785 Front engine PTO, generator preparation 22.5 kW	

24V POWER SUPPLY

Alternator 80 A, batteries 2x 125 Ah..

Optional

01897 Alternator 100 A	08797 Batteries 2x175Ah
-------------------------------	--------------------------------

GVM AND GCM

Chassis weight related technical GVM max 16000 kg; Driveline related technical GCM equal to GVM.

Optional

00738 Driveline related max GCM 24000 kg	00620 Driveline related max GCM 28000 kg
02658 Driveline related max GCM 26000 kg	03700 Driveline related technical GCM = GVM+3500 kg

APPLICATION CONDITIONS

Moisture separator, unheated; Air intake low.

Optional

02270 Cold climate	09960 Air intake on the cab roof
04767 Moisture separator, heated	04987 Radiator flyscreen
04482 Air intake high behind cab	

SERVICE AND MAINTENANCE

Warranty Plus - 1 Year Vehicle & 3 Year Driveline - takes care of all warrantable repairs on the vehicle for one year and on the driveline for second and third years together with associated breakdown coverage.; DAF 2 year Preventive Maintenance Package - 320k.

VEHICLE DELIVERY

Standard toolkit.



Go to [DAF.com](https://www.daf.com) to configure your own perfect DAF.

LF 190

FA 4X2 Rigid, 16t

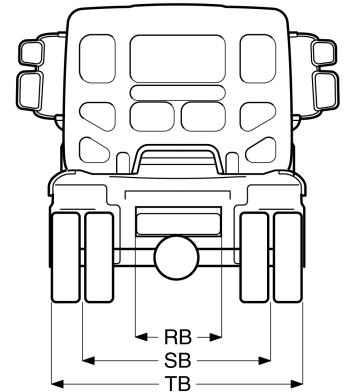
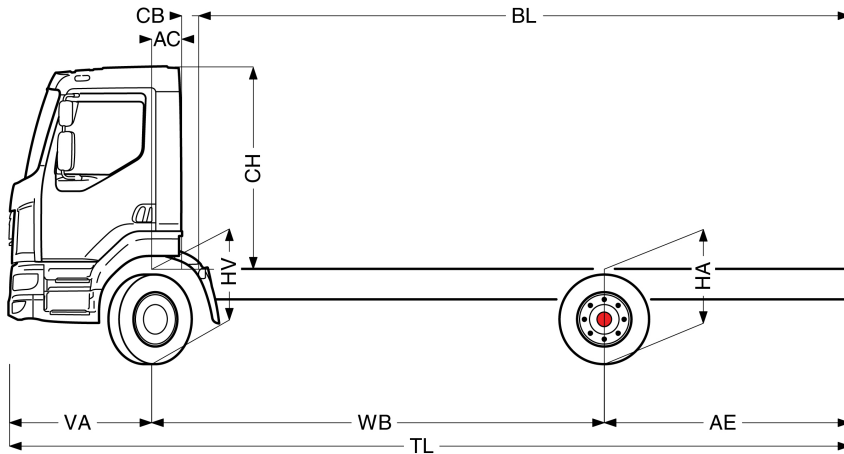

	Wheelbase - AE		Unladen weight ¹⁾			Gross Carrying Capacity			Variable dimensions									
	WB	AE ⁵⁾	Front	Rear	Total	Front	Rear	Total	AC	CB ⁶⁾	CH ⁷⁾	BL ⁸⁾	BL	TL	HA ⁹⁾	HA ¹⁰⁾	TK ¹¹⁾	TW ¹²⁾
DAY CAB	3,25	1,70	2847	1398	4245	3153	9102	11755	0,28	0,12	1,88	3,96	4,23	6,28	1,09	0,94	11,84	12,99
	3,50	1,85	2865	1430	4295	3135	9070	11705	0,28	0,12	1,88	4,33	4,62	6,68	1,09	0,94	12,48	13,65
	3,80	2,03	2863	1432	4296	3137	9068	11704	0,28	0,12	1,88	4,77	5,09	7,16	1,09	0,95	13,26	14,44
	4,20	2,27	2866	1446	4312	3134	9054	11688	0,28	0,12	1,88	5,36	5,70	7,80	1,09	0,95	14,29	15,50
	4,50	2,45	2890	1484	4374	3110	9016	11626	0,28	0,12	1,88	5,80	6,18	8,28	1,09	0,95	15,07	16,29
	4,80	2,63	2887	1490	4377	3113	9010	11623	0,28	0,12	1,88	6,23	6,63	8,76	1,09	0,95	15,86	17,08
	5,35	2,96	2904	1526	4430	3096	8974	11570	0,28	0,12	1,88	7,05	7,49	9,64	1,09	0,95	17,29	18,53
	5,90	3,29	2918	1565	4483	3082	8935	11517	0,28	0,12	1,88	7,85	8,34	10,52	1,09	0,95	18,73	19,99
SLEEPER CAB	6,30	3,53	2925	1585	4510	3075	8915	11491	0,28	0,12	1,88	8,44	8,97	11,16	1,09	0,95	19,78	21,05
	6,70	2,90	3018	1640	4658	2982	8860	11342	0,28	0,12	1,88	9,08	9,65	10,93	1,09	0,97	20,83	22,10
	3,25	1,70	2952	1418	4370	3048	9082	11630	0,68	0,07	1,88	3,30	3,57	6,28	1,09	0,93	11,84	12,99
	3,50	1,85	2972	1449	4421	3028	9051	11579	0,68	0,07	1,88	3,67	3,97	6,68	1,09	0,93	12,48	13,65
	3,80	2,03	2972	1450	4421	3028	9050	11579	0,68	0,07	1,88	4,12	4,43	7,16	1,09	0,93	13,26	14,44
	4,20	2,27	2975	1462	4437	3025	9038	11563	0,68	0,07	1,88	4,71	5,06	7,80	1,09	0,94	14,29	15,50
	4,50	2,45	3001	1499	4500	2999	9001	11500	0,68	0,07	1,88	5,16	5,54	8,28	1,09	0,94	15,07	16,29
	4,80	2,63	2998	1504	4502	3002	8996	11498	0,68	0,07	1,88	5,60	6,00	8,76	1,09	0,94	15,86	17,08
SLEEPER CAB	5,35	2,96	3016	1539	4555	2984	8961	11445	0,68	0,07	1,88	6,42	6,87	9,64	1,09	0,94	17,29	18,53
	5,90	3,29	3033	1576	4608	2967	8924	11392	0,68	0,07	1,88	7,23	7,74	10,52	1,09	0,94	18,73	19,99
	6,30	3,53	3040	1595	4635	2960	8905	11365	0,68	0,07	1,88	7,83	8,36	11,16	1,09	0,94	19,78	21,05
	6,70	2,90	3134	1650	4784	2866	8850	11216	0,68	0,07	1,88	8,49	9,07	10,93	1,09	0,96	20,83	22,10

OTHER DIMENSIONS VA: 1,33 HV¹³⁾: 1,01 HV¹⁴⁾: 0,93 RB: 0,79 SB: 1,75 TB¹⁵⁾: 2,35

- GVM in conformity with registration documents.
- GCM in conformity with registration documents.
- Axle load with standard tyre size.
- Chassis and cab weight calculated with: Standard specification items only with 170 litres of fuel, 30 litres of AdBlue® and driver of 90 kg, tolerance ± 3%. Changing of the specification can have major impact on vehicle weight.
- Other AE dimensions may be available for shown WB. Modify rear overhang to the calculated body length.
- CB is based on standard air intake and/or exhaust.
- Cab height is measured from frame member to closed cabin roof hatch.
- Calculate customer specific body length with TOPEC. Body lengths shown based on evenly distributed load at max axle load.
- Unladen height at centre of driven axle(s).
- Laden height at centre of driven axle(s).
- TK = turning circle between kerbs.
- TW = turning circle between walls.
- Unladen height at centre of front axle(s).
- Laden height at centre of front axle(s).
- TB is overall width at rear. (At centre of front axle 255).

Depending on the vehicle configuration a specific option may not be possible. The availability and specification of this vehicle may differ per country. For further information please contact the DAF organisation. Pictures and technical illustrations are not binding in detail and can differ from the standard specification. Subject to modification without prior notice.