

Specification sheet

XD 410

FTN 6X2 Tractor

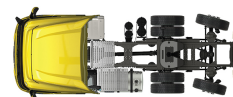

XD

ENGINES

- XD NewGen 370 MX-11 (270 kW / 367 hp)
- XD NewGen 410 MX-11 (300 kW / 408 hp)
- XD NewGen 450 MX-11 (330 kW / 449 hp)

GVM¹⁾

- 26000 kg
- Max. front 8000 kg
- Max. rear 19000 kg

GCM²⁾

- 44000 kg

016GG0121NAAA - 202345C - 18-08-2023

DAF Trucks Ltd, UK, Haddenham, HP17 8LJ, www.daf.co.uk

OPTION PACKAGES

Optional

17448 Safety pack 17595 Executive Pack XD/XF

CAB EXTERIOR

Luxurious Sleeper Cab with unrivalled aerodynamics for fuel efficient driving and low CO2 emissions. The huge and deep frontscreen, curved at the sides combined with large side windows offer an unsurpassed direct view for the driver, to enhance road safety. The cab interior is extremely comfortable for driving, living and sleeping with unprecedented spaciousness and practical layout. Cab length: 2360 mm; cab width: 2500 mm. Number of cab steps: 2.; Cab suspension mechanical; LED head lights; DAF Corner View.

Optional

| | |
|--|--|
| 07017 Day Cab | 00936 Auxiliary LED lights on cab roof, prepared |
| 06244 Sleeper High Cab | 01836 LED Skylights |
| 02889 Chassis front execution: no bottom plate | 00949 LED Skylights; aux. LED lights on cab rf, prepared |
| 02952 Chassis front execution: bottom plate aero | 01925 Two LED work lamps for cab rear wall |
| 03353 Chassis front execution: protruding | 01891 Hazard beacons on cab front, prepared |
| 07586 Chassis front execution: robust | 06629 Two hazard beacon lights |
| 01226 Cab suspension air | 03232 Front windscreen with solar control foil |
| 03358 External sun visor | 03317 Rear window: double glass |
| 06790 Aluminium ladder 1-piece | 07343 Kerb view window co-driver door |
| 06791 Aluminium ladder 2-piece | 01362 DAF Digital Vision System |
| 03922 Fog lights front | |

AERODYNAMICS

Optional

| | |
|---|---|
| 00010 Adj. roof air deflector short Sleeper High Cab | 00118 Adj. roof air deflector for Sleeper Cab |
| 00138 Adj. rf air defl.long mid >4m(!) Sleeper High Cab | 00021 Adj. roof air deflector long low Sleeper High Cab |
| 01552 Adj. roof air defl. long high >4m(!) Sleeper High | 02665 Adj. roof air deflector long mid Sleeper High Cab |
| 00094 Adj. roof air deflector for Day Cab | 04906 Side collars |

COLOURS

Cab colour E1980 Crystal White; Chassis colour grey.; Colour of bumper: Crystal White.

CAB INTERIOR

Cab interior trim colour: Luxury; Dashboard finish: Vision; Cab interior decoration: Hexagon; Driver seat: Comfort Air; Co-driver seat: cinema with fabric cover; Dashboard table; Storage compartment in centre; Automatic Temperature Control and aircoc; Auxiliary cab heater (water).

Optional

| | |
|---|--|
| 02353 Cab interior decoration: Argenta | 03948 Single drawer |
| 02350 Cab interior decoration: Natura | 03954 Refrigerator |
| 07733 Driver seat: Luxury Air | 31364 Without feature: Lower bunk mattress |
| 07736 Driver seat: Super Air | 02854 Xtra Comfort mattress for lower bunk |
| 07737 Driver seat: Xtra Leather Air | 01775 Xtra Comfort mattress with topper for lower bunk |
| 09541 Arm rest driver seat | 01177 Luggage carrier |
| 01740 Arm rest at both sides of the driver seat | 01066 Upper bunk |
| 02117 Third seat | 06970 Automatic Cab Climate Control |
| 02834 No dashboard table | |

COMMUNICATION AND DRIVING MANAGEMENT

DAF Connect; Tachograph digital, Stoneridge 1C version G2V2; Speed limiter setting 85 km/h; Eco off 90 km/h; DAF Infotainment Luxury with Luxury speakers; Adaptive Cruise Control with FCW and AEBS-3.

Optional

| | |
|--|--|
| 09681 Preparation for Maut | 01915 DAF Infotainment System: Luxury Plus |
| 06211 DAF Infotainment System with FM/DAB/DAB+ radio | 16155 Audio equipment, makes and types |
| 03470 DAF Infotainment System: Exclusive, prepared | 06991 Predictive Cruise Control |

SAFETY AND SECURITY

Lane Departure Warning System; Vehicle Stability Control (VSC); Basic engine immobiliser system; DAF Side & Turn Assist.

Optional

| | |
|---|---------------------------------|
| 08631 Air bag (driver) and 2 seat belt tensioners | 00795 Safety regulations EC ADP |
| 02178 Main switch with second control in the cab | |

SUSPENSION AND AXLES

Front: 8.00 t, parabolic, 163N; Rear axle load 13.00 t; Rear: 20.00 t, air suspension, SR1344; Trailing axle load 8.0t; Lifting device.

Optional

| | |
|------------------------------|----------------------------|
| 06257 Front axle load 9.00 t | 04057 Rear axle HR1356 |
| 04647 Front springs air | 08191 Axle load monitoring |

WHEELS AND TYRES

Driven rear axle(s): 315/70R22.5; F1,315/70R22.5GO FMXSE 156/150 L Steering BBA 3P; R1,315/70R22.5GO FMXDE 154/150 L Traction BBA 3P; R2,315/70R22.5GO FMXSE 156/150 L Steering BBA 3P.

Optional

16152 Tyre makes and types

DRIVELINE

Engine MX-11, multi torque 6 cylinder diesel engine, 10.8 litres. Output 300 kW (408 hp) at 1600 rpm. Maximum torque 2150 Nm at 900-1125 rpm.; Exhaust emission Euro 6; Eco fuel; 12-speed TraXon 12TX2010 DD, 16.69-1.00; Gearbox ratio 16.69-1.00; Rear axle ratio 2.38; ASR.

Optional

| | |
|---|--|
| 07110 Eco performance | 08371 Long Combination Vehicle (LCV) |
| 02314 Gearbox overdrive | 09638 Off-road applications |
| 01514 Urge-to-move | 01498 Off-road applications with Rock-free function |
| 07101 Standard transport, Lite version | 02843 Mechanical differential lock |
| 09637 Liquid transport | |

BRAKE SYSTEM

MX Engine Brake; Ventilated disc brakes front and rear. Dual circuit air system with electronic control (EBS)..

Optional

| | |
|---|---|
| 09920 No MX Engine Brake | 01497 Park brake control pneumatic with spoken warning |
| 02715 ZF Intarder | |
| 01572 Park brake control electro-pneumatic | 04901 Spring brake cylinders on the first front axle |

CHASSIS

Wheelbase 3.40 m / rear overhang 0.84 m; Side member height 260 mm; 430 l alu fuel tank LH, height 620 mm; Tank for AdBlue® 40 l, on left-hand mudguard; Front underrun protection (FUP); Catwalk with step; Rear mudguards; Spray suppression; Work lamp LED.

Optional

| | |
|---|-----------------------------------|
| 02601 Side member height 310 mm | 03323 Rear light with LEDs |
| 16157 Fuel tanks, material and sizes | |

DRAWBAR AND TRAILER EQUIPMENT

JOST JSK36DV pressed steel 205+40mm; Pneumatic trailer connection C-type; Electric connection 24 V / 2x7 pins.

Optional

| | |
|--|--|
| 03178 Towing hook D= 4.3 | 16151 5th wheel makes and heights |
| 07033 Trailer coupling Ringfeder D=13.7 | |

BODIES AND PREPARATIONS FOR BODYING

Optional

| | |
|--|--|
| 02811 Tail lift connection Anderson | 02812 Tail lift connection REMA |
|--|--|

POWER TAKE-OFF (PTO)

Optional

| |
|--------------------------------------|
| 16148 PTO types and positions |
|--------------------------------------|

24V POWER SUPPLY

Alternator 130 A, batteries 2x 175 Ah..

Optional

| | |
|--------------------------------|---|
| 08775 Alternator 150 A | 07671 Batteries 2x210Ah AGM C-type |
| 01257 Batteries 2x140Ah | 06440 Batteries 2x230Ah |

GVM AND GCM

Chassis weight related technical GVM max 27000 kg; Driveline related max GCM 44000 kg class 2.

APPLICATION CONDITIONS

Air intake front.

Optional

| | |
|---------------------------------------|---------------------------------------|
| 02260 Extra cab insulation | 06614 Anti-dust blow-up shield |
| 03648 Cyclonic air intake high | |

SERVICE AND MAINTENANCE

Standard Warranty takes care of 1 year complete vehicle as supplied by the OEM (excl. real wear parts), 2nd year driveline and 1st year breakdown.; ITS service.

Optional

| |
|--|
| 08311 Service interval extended |
|--|

VEHICLE DELIVERY

Minimum toolkit.

Optional

| |
|---------------------------|
| 07569 Lifting jack |
|---------------------------|



Go to [DAF.com](https://www.daf.com) to configure your own perfect DAF.

XD 410

FTN 6X2 Tractor

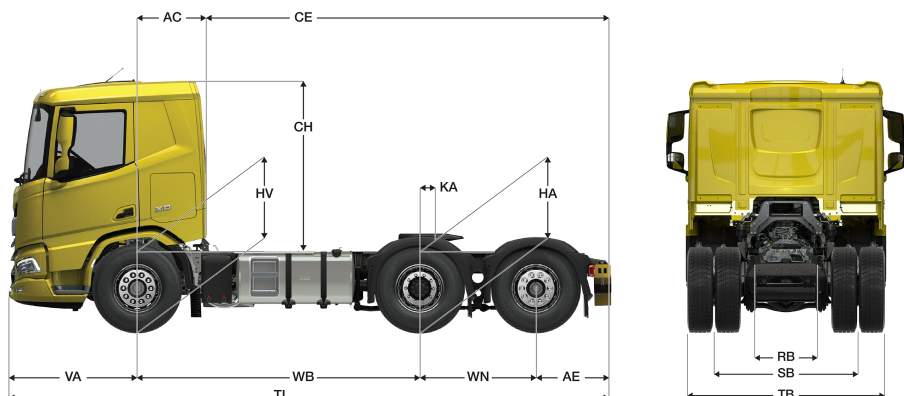

| | Wheelbase - AE | | Unladen weight ¹⁾ | | | Gross Carrying Capacity | | | Variable dimensions | | | | | | | | |
|------------------|----------------|------------------|------------------------------|------|-------|-------------------------|-------|-------|---------------------|------|------|------------------|------|------------------|------------------|------------------|-------------------|
| | WB | AE ⁵⁾ | Front | Rear | Total | Front | Rear | Total | AC | CE | CH | KA ⁶⁾ | TL | HA ⁷⁾ | HA ⁸⁾ | TK ⁹⁾ | TW ¹⁰⁾ |
| DAY CAB | 3,40 | 0,84 | 4687 | 3430 | 8117 | 3313 | 15570 | 17883 | 0,50 | 5,14 | 2,06 | -0,03 | 7,17 | 0,97 | 0,95 | 12,47 | 13,82 |
| | 3,70 | 1,10 | 4685 | 3409 | 8094 | 3315 | 15591 | 17906 | 0,50 | 5,70 | 2,01 | 0,00 | 7,73 | 1,02 | 0,99 | 13,24 | 14,62 |
| SLEEPER CAB | 3,40 | 0,84 | 4826 | 3433 | 8259 | 3174 | 15567 | 17741 | 0,83 | 4,81 | 2,06 | -0,03 | 7,17 | 0,97 | 0,94 | 12,47 | 13,82 |
| | 3,70 | 1,10 | 4787 | 3377 | 8164 | 3213 | 15623 | 17836 | 0,83 | 5,37 | 2,01 | 0,00 | 7,73 | 1,02 | 0,99 | 13,24 | 14,62 |
| SLEEPER HIGH CAB | 3,40 | 0,84 | 4856 | 3432 | 8288 | 3144 | 15568 | 17712 | 0,83 | 4,81 | 2,54 | -0,03 | 7,17 | 0,97 | 0,94 | 12,47 | 13,82 |
| | 3,70 | 1,10 | 4817 | 3376 | 8194 | 3183 | 15624 | 17806 | 0,83 | 5,37 | 2,49 | 0,00 | 7,73 | 1,02 | 0,99 | 13,24 | 14,62 |

OTHER DIMENSIONS VA: 1,53 WN: 1,40 HV¹¹⁾: 0,97 HV¹²⁾: 0,90 RB: 0,79 SB: 1,82 TB¹³⁾: 2,48

1) GVM in conformity with registration documents.
 2) GCM in conformity with registration documents.
 3) Axle load with standard tyre size.
 4) Chassis and cab weight calculated with: Standard specification items only with 430 litres of fuel, 40 litres of AdBlue® and driver of 90 kg, tolerance ± 3%. Changing of the specification can have major impact on vehicle weight.
 5) Other AE dimensions may be available for shown WB.
 6) Calculate customer specific KA with TOPEC.

7) Unladen height at centre of driven axle(s).
 8) Laden height at centre of driven axle(s).
 9) TK = turning circle between kerbs.
 10) TW = turning circle between walls.
 11) Unladen height at centre of front axle(s).
 12) Laden height at centre of front axle(s).
 13) TB is overall width at rear. (At centre of front axle 255).

Depending on the vehicle configuration a specific option may not be possible. The availability and specification of this vehicle may differ per country. For further information please contact the DAF organisation. Pictures and technical illustrations are not binding in detail and can differ from the standard specification. Subject to modification without prior notice.