

Specification sheet

XF Electric FTN (6x2)

FTN 6X2 Tractor, Electric



ENGINES

- XF 270e EX-D2 (270kW)
- XF 310e EX-D2 310kW)
- XF 350e EX-D2 (350kW)

GVM¹⁾

28000 kg

Max. front 8000 kg

Max. rear 20300 kg

GCM²⁾

46000 kg

991GG220NAAA - 202621F - 28-01-2026

DAF Trucks N.V., The Netherlands, www.daf.com

CAB EXTERIOR

Luxurious Sleeper Cab with unrivalled aerodynamics for fuel efficient driving and low CO2 emissions. The huge and deep frontscreen, curved at the sides combined with large side windows offer an unsurpassed direct view for the driver, to enhance road safety. The cab interior is extremely comfortable for driving, living and sleeping with unprecedented spaciousness and practical layout. Cab length: 2360 mm; cab width: 2500 mm. Number of cab steps: 3.; Cab suspension mechanical; LED head lights; Front view mirror.

Optional

06244 Sleeper High Cab	00949 LED Skylights; aux. LED lights on cab rf, prepared
02889 Chassis front execution: no bottom plate	01925 Two LED work lamps for cab rear wall
02952 Chassis front execution: bottom plate aero	01891 Hazard beacons on cab front, prepared
07586 Chassis front execution: robust	06629 Two hazard beacon lights
03358 External sun visor	03232 Front windscreen with solar control foil
06790 Aluminium ladder 1-piece	03317 Rear window: double glass
06791 Aluminium ladder 2-piece	07343 Kerb view window co-driver door
03922 Fog lights front	01550 No front view mirror
00936 Auxiliary LED lights on cab roof, prepared	01362 DAF Digital Vision System
01836 LED Skylights	01913 DAF Corner View

AERODYNAMICS

Optional

00010 Adj. roof air deflector short Sleeper High Cab	00118 Adj. roof air deflector for Sleeper Cab
01904 Adj. rf air defl. long low >4m(!) XF Sl. High Cab	00021 Adj. roof air deflector long low Sleeper High Cab
00138 Adj. rf air defl.long mid >4m(!) Sleeper High Cab	04906 Side collars, one side hinged
01552 Adj. roof air defl. long high >4m(!) Sleeper High	03074 Side collars, both sides hinged

COLOURS

Cab colour E1980 Crystal White; Chassis colour grey.; Colour of bumper: Crystal White.

CAB INTERIOR

Cab interior trim colour: Luxury; Dashboard finish: Vision; Cab interior decoration: Hexagon; Driver seat: Comfort Air; Arm rest driver seat; Co-driver seat: cinema with fabric cover; Dashboard table; Storage compartment in centre; Automatic Temperature Control and airco; Auxiliary cab heater (water).

Optional

07310 Steering wheel, black	04070 Two drawers
02355 Steering wheel, leather	03954 Refrigerator
02146 Dashboard finish: Plateau	04050 Refrigerator and drawer
02353 Cab interior decoration: Argenta	04069 Two refrigerators
02350 Cab interior decoration: Natura	02854 Xtra Comfort mattress for lower bunk
07733 Driver seat: Luxury Air	01775 Xtra Comfort mattress with topper for lower bunk
07736 Driver seat: Super Air	01177 Luggage carrier
07737 Driver seat: Xtra Leather Air	01066 Upper bunk
03948 Single drawer	06970 Automatic Cab Climate Control

COMMUNICATION AND DRIVING MANAGEMENT

PACCAR Connect; Tachograph digital, Stoneridge version G2V2A; Speed limiter setting 85/90 km/h; Adaptive Cruise Control with FCW and AEBS-3; Driver Performance Assistant.

Optional

09681 Preparation for Maut	16161 No audio equipment, makes and types
04553 Infotainment incl. DAF Truck Nav. and tablet prep.	06991 Predictive Cruise Control
03684 Infotainment including DAF Truck Navigation	06992 Predictive Cruise Control lite

SAFETY AND SECURITY

DAF drowsiness & distraction detection; Lane Departure Warning System; Vehicle Stability Control (VSC); Basic engine immobiliser system.

Optional

08631 Air bag (driver) and 2 seat air suspension, SR1344;	01952 No DAF Side/Turn Assist belt tensioners
02569 No Driver State Monitoring	

SUSPENSION AND AXLES

Front: 8.00 t, parabolic, 163N; Rear axle load 13.00 t; Rear: 20.00 t, air suspension, SR1344; Trailing axle load 8.0t; Lifting device.

Optional

06257 Front axle load 9.00 t	04588 Rear axle SR1347
06095 Front axle load 10.00 t	08191 Axle load monitoring
04647 Front springs air	

WHEELS AND TYRES

Driven rear axle(s): 315/70R22.5; F1,315/80R22.5GO EQMSU 158/150 L Steering ABA 3P; R1,315/70R22.5GO EQMD 154/150 L Traction BBB 3P; R2,315/70R22.5GO EQMS 158/150 L Steering BBA 3P.

Optional

16152 Tyre makes and types

DRIVELINE

No engine.; Electric motor type EX-D2; 310 kW; 150 kW DC charging; Battery Electric Vehicle; Rear axle ratio 2.21; ASR.

Optional

01686 270 kW	01756 325 kW DC charging
01692 350 kW	03677 Charging: 325 kW DC + 22 kW AC
01749 Charging: 150 kW DC + 22 kW AC	02843 Mechanical differential lock

BRAKE SYSTEM

Ventilated disc brakes front and rear. Dual circuit air system with electronic control (EBS).Engine driven, water cooled aire compressor with automatic air h eated dryer..

Optional

04901 Spring brake cylinders on the first front axle

CHASSIS

Wheelbase 4.00 m / rear overhang 0.84 m; Side member height 260 mm; Standard component location; 4 HV battery packs; HV battery packs left, positions 1 and 2; HV battery pack right, position 1; Front underrun protection (FUP); Catwalk with step; Rear mudguards; Spray suppression; Work lamp LED.

Optional

01697 3 HV battery packs	01785 HV battery pack right, position 2
01701 5 HV battery packs	
01634 HV battery pack left, position 1	01791 HV battery packs right, positions 1 and 2
01635 HV battery pack left, position 2	16157 Fuel tanks, material and sizes

DRAWBAR AND TRAILER EQUIPMENT

Fontaine 150SP2 pressed steel 185+40mm; Pneumatic trailer connection palm type; Electric connection 24 V / 2x7 pins.

Optional

03178 Towing hook D= 4.3	16151 5th wheel makes and heights
---------------------------------	--

BODIES AND PREPARATIONS FOR BODYING

Optional

02811 Tail lift connection Anderson	02812 Tail lift connection REMA
--	--

POWER TAKE-OFF (PTO)

Optional

01809 ePTO socket 650V DC < 25 kW	04320 ePTO socket 650V DC < 90 kW
--	--

24V POWER SUPPLY

Batteries 2x 175 Ah..

Optional

07671 Batteries 2x210Ah AGM C-type	06440 Batteries 2x230Ah
---	--------------------------------

GVM AND GCM

Chassis weight related technical GVM max 28000 kg; Driveline related max GCM 46000 kg.

APPLICATION CONDITIONS

Optional

02260 Extra cab insulation

SERVICE AND MAINTENANCE

Standard Warranty takes care of 1 year complete vehicle as supplied by the OEM (excl. real wear parts), 2nd year driveline and 1st year breakdown.; ITS service.

VEHICLE DELIVERY

Minimum toolkit.

Optional

07569 Lifting jack

OPTION PACKAGES

Optional

17448 Safety pack	17595 Executive Pack XD/XF
--------------------------	-----------------------------------

Go to [DAF.com](https://www.daf.com) to configure your own perfect DAF.

XF

FTN 6X2 Tractor, Electric

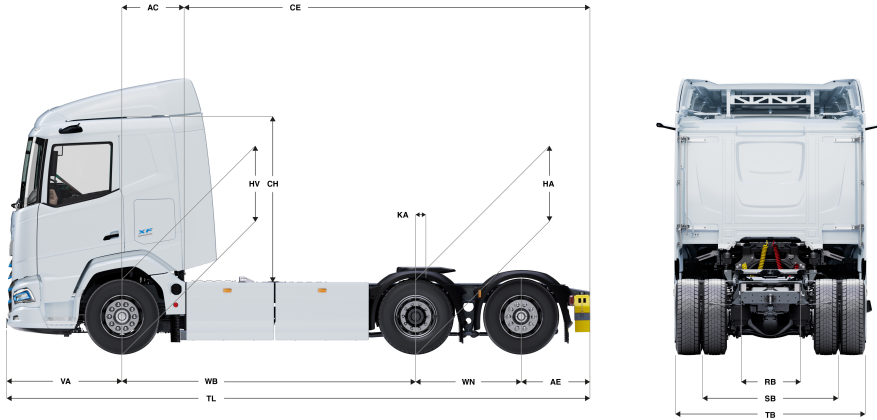

	Wheelbase - AE		Unladen weight ¹⁾			Gross Carrying Capacity			Variable dimensions								
	WB	AE ⁵⁾	Front	Rear	Total	Front	Rear	Total	AC	CE	CH ⁶⁾	KA ⁷⁾	TL	HA ⁸⁾	HA ⁹⁾	TK ¹⁰⁾	TW ¹¹⁾
SLEEPER CAB	4,00	0,84	6797	4279	11076	1203	16021	16924	0,83	5,41	2,18	-0,53	7,77	1,02	1,00	14,02	15,41
SLEEPER HIGH CAB	4,00	0,84	6828	4279	11107	1172	16021	16893	0,83	5,41	2,66	-0,53	7,77	1,02	1,00	14,02	15,41

OTHER DIMENSIONS

VA: 1,53 WN: 1,40 HV¹²⁾: 1,03 HV¹³⁾: 0,97 RB: 0,79 SB: 1,82 TB¹⁴⁾: 2,48

- 1) GVM in conformity with registration documents.
- 2) GCM in conformity with registration documents.
- 3) Axle load with standard tyre size.
- 4) Chassis and cab weight calculated with: Standard specification items only with 0 litres of fuel, 0 litres of AdBlue® and driver of 0 kg, tolerance ± 3%. Changing of the specification can have major impact on vehicle weight.
- 5) Other AE dimensions may be available for shown WB.
- 6) Cab height is measured from frame member to closed cabin roof hatch.
- 7) Calculate customer specific KA with TOPEC.

- 8) Unladen height at centre of driven axle(s).
- 9) Laden height at centre of driven axle(s).
- 10) TK = turning circle between kerbs.
- 11) TW = turning circle between walls.
- 12) Unladen height at centre of front axle(s).
- 13) Laden height at centre of front axle(s).
- 14) TB is overall width at rear. (At centre of front axle 255).

Depending on the vehicle configuration a specific option may not be possible. The availability and specification of this vehicle may differ per country. For further information please contact the DAF organisation. Pictures and technical illustrations are not binding in detail and can differ from the standard specification. Subject to modification without prior notice.