

Specification sheet

XF 450

FTN 6X2 Tractor



ENGINES

- XF 450 MX-11 (330 kW / 449 hp)
- XF 430 MX-13 (315 kW / 428 hp)
- XF 480 MX-13 (355 kW / 483 hp)
- XF 530 MX-13 (390 kW / 530 hp)

GVM¹⁾

- 26000 kg
- Max. front 8000 kg
- Max. rear 18999 kg

GCM²⁾

- 44000 kg

016G0729NAAA - 202345C - 18-08-2023

DAF Trucks Ltd, UK, Haddenham, HP17 8LJ, www.daf.co.uk

CAB EXTERIOR

Space Cab with galvanised steel bumper, tinted glass and electric window openers. Main mirrors and wide angle mirrors electrically heated. Cab width 2490 mm.; Cab suspension mechanical; LED daytime running lights; Front view mirror; Central door lock system, 2 keys, 2 RC units.

Optional

01760 Super Space Cab	08020 LED head lights
01226 Cab suspension air	09982 No auxiliary lights in the bumper
01174 External sun visor green translucent	09984 Fog lights and cornering lights
06790 Aluminium ladder 1-piece	06593 Skylights
06791 Aluminium ladder 2-piece	06628 One hazard beacon light at co-driver side
00847 Air horns, single set	06627 One hazard beacon light at driver side
09006 Air horns, double set	06629 Two hazard beacon lights

AERODYNAMICS

Optional

08823 Adj. roof air deflector Space Cab; over 4 m (!)	06904 Fixed rf deflector; total height over 4 m
06776 Adjustable roof air deflector	07401 Winding handle for roof air deflector
08822 Adj. roof air deflector for Space Cab	04906 Side collars
06160 Fixed roof air deflector for Super Space Cab	

COLOURS

Cab colour H3279 Brilliant White; Head lamp panel and bumper: Brilliant White; Chassis colour grey..

CAB INTERIOR

Cab interior trim colour Dark Sand; Cab interior decoration Delta black; Driver seat: Comfort Air; Co-driver seat: basic; Lower bunk without drawer; Luggage carrier; Automatic Temperature Control and airco; Auxiliary cab heater (water); Pollen filter.

Optional

07152 Cab interior trim colour Exclusive	07748 Co-driver seat: Xtra Leather Air
07592 Cab interior decoration Argenta	00967 Seat belts red
07591 Cab interior decoration Rustica	06539 Refrigerator
07733 Driver seat: Luxury Air	09603 Lower bunk with drawer 65 litres
07736 Driver seat: Super Air	06784 Lower bunk mattress Xtra Comfort
07737 Driver seat: Xtra Leather Air	01065 No upper bunk / no luggage carrier
07741 Co-driver seat: Comfort Air	01066 Upper bunk
07743 Co-driver seat: Luxury Air	06676 PL light in cab ceiling
07746 Co-driver seat: Super Air	06970 Automatic Cab Climate Control

COMMUNICATION AND DRIVING MANAGEMENT

Tachograph digital, Stoneridge 1C version G2V2; Speed limiter setting 85 km/h; Eco off 90 km/h; Antennas: radio, 2x cellular, GNSS; Adaptive Cruise Control with FCW and AEBS-3; Driver Performance Assistant.

Optional

09681 Preparation for Maut	06991 Predictive Cruise Control
07117 Radio/USB player, 2 speakers	

SAFETY AND SECURITY

Lane Departure Warning System; Vehicle Stability Control (VSC); Basic engine immobiliser system.

Optional

08631 Air bag (driver) and 2 seat belt tensioners	09828 Front camera system
07011 DAF Night Lock	09827 Side camera system
02178 Main switch with second control in the cab	01725 Reverse warning

SUSPENSION AND AXLES

Front axle load 8.00 t; Rear: 11.50 + 7.50 t, air suspension, SR1344.

Optional

06257 Front axle load 9.00 t	04588 Rear axle SR1347
04647 Front springs air	01946 Rear axle load 12.00+ 7.40 t
04057 Rear axle HR1356	08191 Axle load monitoring

WHEELS AND TYRES

Front axle(s): 315/80R22.5; Driven rear axle(s): 315/80R22.5; Second driven rear or trailing axle: 315/80R22.5; Disc wheels steel, silvergrey; Wheel protection rings silvergrey.

Optional

16152 Tyre makes and types

DRIVELINE

Engine MX-11, multi torque 6 cylinder diesel engine, 10.8 litres. Output 330 kW (449 hp) at 1600 rpm. Maximum torque 2300 Nm at 900-1125 rpm.; Exhaust emission Euro 6; Engine idle shutdown, 5 minutes; Automated gearbox, TraXon, 12 speeds; Gearbox ratio 16.69-1.00; Rear axle ratio 2.47; ASR.

Optional

04523 Manual gearbox, 16 speeds	02314 Gearbox overdrive
07103 Automated gearbox, TraXon, 16 speeds	

BRAKE SYSTEM

MX Engine Brake; Park brake control with test position; Ventilated disc brakes front and rear. Dual circuit air system with electronic control (EBS). Twin cylinder air compressor with heated dryer and economy mode..

Optional

09920 No MX Engine Brake	04901 Spring brake cylinders on the first front axle
02715 ZF Intarder	

CHASSIS

Wheelbase 3.40 m / rear overhang 0.84 m; Side member height 260 mm; Exhaust pipe horizontal, low; Vert battery box left, no spare wheel carrier; Aluminium fuel tank 430 l, height 620 mm; Tank for AdBlue® 90 l, on left-hand mudguard; Front underrun protection (FUP); Catwalk with step; Rear mudguards; Spray suppression; Work lamp LED.

Optional

02601 Side member height 310 mm	16157 Fuel tanks, material and sizes
06611 Exhaust pipe vertical, high	03323 Rear light with LEDs

DRAWBAR AND TRAILER EQUIPMENT

Fifth wheel JOST type JSK42, cast iron, height 185 mm with 40 mm mounting plate. King pin diameter 2 inches.; Fifth wheel KA dimension -30 mm; Pneumatic trailer connection C-type; Electric connection 24 V / 2x7 pins; Trailer connection storage box.

Optional

- | | |
|--|--|
| 03178 Towing hook D= 4.3 | 08026 Trailer coupling Rockinger D=13.0 |
| 07033 Trailer coupling Ringfeder D=13.7 | 16151 5th wheel makes and heights |

POWER TAKE-OFF (PTO)

Optional

- 16148** PTO types and positions

24V POWER SUPPLY

Alternator 120 A, batteries 2x 230 Ah..

Optional

- | | |
|-------------------------------|---|
| 08775 Alternator 150 A | 07671 Batteries 2x210Ah AGM C-type |
|-------------------------------|---|

GVM AND GCM

Chassis weight related technical GVM max 27000 kg; Driveline related max GCM 50000 kg class 3.

Optional

- | | |
|---|---|
| 03673 Driveline related max GCM 44000 kg class 2 | 00818 Driveline related max GCM 60000 kg class 3 |
| 00939 Driveline related max GCM 56000 kg class 2 | |

APPLICATION CONDITIONS

Air intake high.

Optional

- | | |
|-------------------------------|---------------------------------------|
| 08400 Silent mode | 03648 Cyclonic air intake high |
| 03646 Air intake front | |

SERVICE AND MAINTENANCE

Standard Warranty takes care of 1 year complete vehicle as supplied by the OEM (excl. real wear parts), 2nd year driveline and 1st year breakdown.; ITS service.

Optional

- 08311** Service interval extended



Go to [DAF.com](https://www.daf.com) to configure your own perfect DAF.

XF 450

FTN 6X2 Tractor

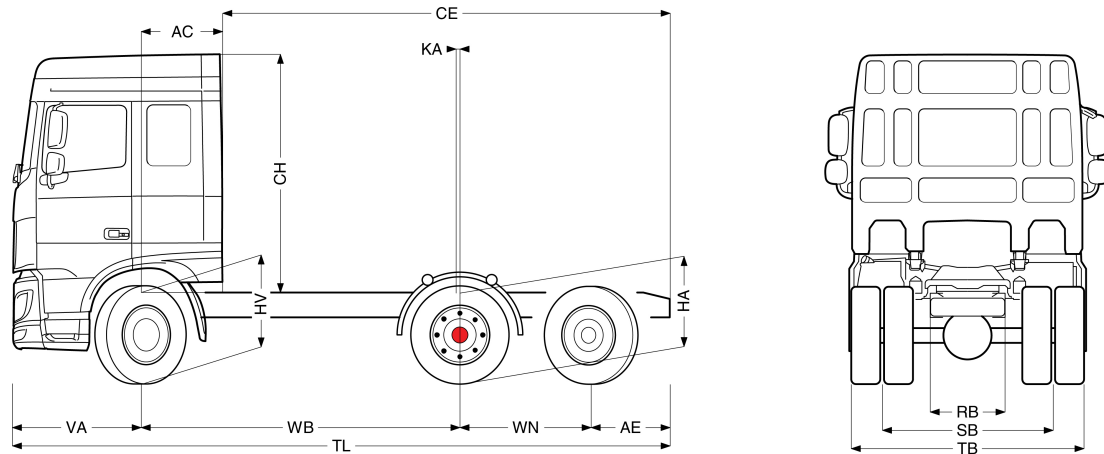

	Wheelbase - AE		Unladen weight ¹⁾			Gross Carrying Capacity			Variable dimensions								
	WB	AE ⁵⁾	Front	Rear	Total	Front	Rear	Total	AC	CE	CH	KA ⁶⁾	TL	HA ⁷⁾	HA ⁸⁾	TK ⁹⁾	TW ¹⁰⁾
SPACE CAB	3,40	0,84	5219	3464	8683	2781	15534	17317	0,88	4,76	2,56	-0,03	7,01	1,00	0,97	12,47	13,81
	3,70	1,10	5184	3397	8581	2816	15602	17419	0,88	5,32	2,51	0,00	7,57	1,05	1,02	13,25	14,60
SUPER SPACE CAB	3,40	0,84	5292	3459	8751	2708	15540	17249	0,88	4,76	2,94	-0,03	7,01	1,00	0,97	12,47	13,81
	3,70	1,10	5257	3392	8650	2743	15606	17350	0,88	5,32	2,89	0,00	7,57	1,05	1,02	13,25	14,60

OTHER DIMENSIONS VA: 1,37 WN: 1,40 HV¹¹⁾: 1,00 HV¹²⁾: 0,93 RB: 0,79 SB: 1,82 TB¹³⁾: 2,48

1) GVM in conformity with registration documents.
 2) GCM in conformity with registration documents.
 3) Axle load with standard tyre size.
 5) Other AE dimensions may be available for shown WB.
 6) Calculate customer specific KA with TOPEC.

7) Unladen height at centre of driven axle(s).
 8) Laden height at centre of driven axle(s).
 9) TK = turning circle between kerbs.
 10) TW = turning circle between walls.
 11) Unladen height at centre of front axle(s).
 12) Laden height at centre of front axle(s).
 13) TB is overall width at rear. (At centre of front axle 255).

Depending on the vehicle configuration a specific option may not be possible. The availability and specification of this vehicle may differ per country. For further information please contact the DAF organisation. Pictures and technical illustrations are not binding in detail and can differ from the standard specification. Subject to modification without prior notice.