

Specification sheet

XFC 410

FT 4X2 Tractor

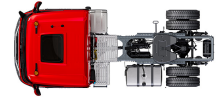

ENGINES

XFC NewGen 370 MX-11 (270 kW / 367 hp)
XFC NewGen 410 MX-11 (300 kW / 408 hp)
XFC NewGen 450 MX-11 (330 kW / 449 hp)
XFC NewGen 430 MX-13 (315 kW / 428 hp)
XFC NewGen 480 MX-13 (355 kW / 483 hp)
XFC NewGen 530 MX-13 (390 kW / 530 hp)

GVM¹⁾

18000 kg
Max. front 8000 kg
Max. rear 11500 kg

GCM²⁾

44000 kg

016GG0209CAAAA - 202545A - 15-07-2025

DAF Trucks Ltd, UK, Haddenham, HP17 8LJ, www.daf.co.uk

CAB EXTERIOR

Luxurious Sleeper Cab with unrivalled aerodynamics for fuel efficient driving and low CO2 emissions. The huge and deep frontscreen, curved at the sides combined with large side windows offer an unsurpassed direct view for the driver, to enhance road safety. The cab interior is extremely comfortable for driving, living and sleeping with unprecedented spaciousness and practical layout. Cab length: 2360 mm; cab width: 2500 mm. Number of cab steps: 3.; Cab suspension mechanical; LED head and fog lights; Front view mirror.

Optional

07017 Day Cab	01925 Two LED work lamps for cab rear wall
06244 Sleeper High Cab	01891 Hazard beacons on cab front, prepared
03358 External sun visor	06629 Two hazard beacon lights
04291 Cab step flexible	03232 Front windscreen with solar control foil
06790 Aluminium ladder 1-piece	03317 Rear window: double glass
06791 Aluminium ladder 2-piece	07343 Kerb view window co-driver door
00936 Auxiliary LED lights on cab roof, prepared	01550 No front view mirror
01836 LED Skylights	01362 DAF Digital Vision System
00949 LED Skylights; aux. LED lights on cab rf, prepared	01913 DAF Corner View

AERODYNAMICS

Optional

00010 Adj. roof air deflector short Sleeper High Cab	03419 Side collars, extended. One side hinged
01904 Adj. rf air defl. long low >4m(!) XF Sl. High Cab	03076 Side collars, extended. Both sides hinged
00138 Adj. rf air defl. long mid >4m(!) Sleeper High Cab	04146 Side skirts
01552 Adj. roof air defl. long high >4m(!) Sleeper High	01122 Side skirts
00094 Adj. roof air deflector for Day Cab	01126 Side skirts with bottom extensions
00118 Adj. roof air deflector for Sleeper Cab	01127 Side skirts with top extensions
04906 Side collars, one side hinged	01135 Side skirts with extensions at top and bottom
03074 Side collars, both sides hinged	

COLOURS

Cab colour E1980 Crystal White; Chassis colour grey.; Colour of bumper: grey.

CAB INTERIOR

Cab interior trim colour: Luxury; Dashboard finish: Vision; Cab interior decoration: Hexagon; Driver seat: Comfort Air; Arm rest driver seat; Co-driver seat: cinema with fabric cover; Dashboard table; Storage compartment in centre; Automatic Temperature Control and airco; Auxiliary cab heater (water).

Optional

07310 Steering wheel, black	03954 Refrigerator
02355 Steering wheel, leather	04050 Refrigerator and drawer
02146 Dashboard finish: Plateau	04069 Two refrigerators
02353 Cab interior decoration: Argenta	31364 Without feature: Lower bunk mattress
02350 Cab interior decoration: Natura	02854 Xtra Comfort mattress for lower bunk
07733 Driver seat: Luxury Air	01775 Xtra Comfort mattress with topper for lower bunk
07736 Driver seat: Super Air	01177 Luggage carrier
07737 Driver seat: Xtra Leather Air	01066 Upper bunk
02117 Third seat	06970 Automatic Cab Climate Control
03948 Single drawer	01967 Park air conditioning, integrated
04070 Two drawers	

COMMUNICATION AND DRIVING MANAGEMENT

PACCAR Connect; Tachograph digital, Stoneridge version G2V2A; Speed limiter setting 85/90 km/h; Adaptive Cruise Control with FCW and AEBS-3; Driver Performance Assistant.

Optional

09681 Preparation for Maut	03684 Infotainment including DAF Truck Navigation
03470 Infotainment incl. DAF Truck Nav. and tablet prep.	16161 No audio equipment, makes and types

SAFETY AND SECURITY

DAF drowsiness detection; Lane Departure Warning System; Vehicle Stability Control (VSC); Basic engine immobiliser system.

Optional

08631 Air bag (driver) and 2 seat belt tensioners	06410 Safe Load Pass preparation
02178 Main switch with second control in the cab	00795 Safety regulations EC ADR
02569 No Driver State Monitoring	01952 No DAF Side/Turn Assist
03628 DAF drowsiness & distraction detection	

SUSPENSION AND AXLES

Front: 8.00 t, parabolic, 167N; Rear axle load 13.00 t; Rear: air suspension, SR1344; No lifting device.

Optional

06257 Front axle load 9.00 t	04588 Rear axle SR1347
04057 Rear axle HR1356	08191 Axle load monitoring

WHEELS AND TYRES

Driven rear axle(s): 315/80R22.5; F1,315/80R22.5GO OMTS 156/150 K Steering DBB; R1,315/80R22.5GO OMTD 156/150 K Traction DBB.

Optional

16152 Tyre makes and types

DRIVELINE

Engine MX-11, multi torque 6 cylinder diesel engine, 10.8 litres. Output 300 kW (408 hp) at 1600 rpm. Maximum torque 2150 Nm at 900-1125 rpm.; Exhaust emission Euro 6; Eco fuel; 12-speed TraXon 12TX2010 DD, 16.69-1.00; Gearbox ratio 16.69-1.00; Rear axle ratio 2.47; ASR.

Optional

07110 Eco performance	08371 Long Combination Vehicle (LCV)
02314 Gearbox overdrive	
09636 Heavy haulage	09638 Off-road applications
09637 Liquid transport	01498 Off-road applications with Rock-free function

BRAKE SYSTEM

MX Engine Brake; Ventilated disc brakes front and rear. Dual circuit air system with electronic control (EBS). Engine driven, water cooled aire compressor with automatic air heated dryer..

Optional

02715 ZF Intarder	01497 Park brake control pneumatic with spoken warning
01572 Park brake control electro-pneumatic	
	04901 Spring brake cylinders on the first front axle

CHASSIS

Wheelbase 3.80 m / rear overhang 0.99 m; Side member height 260 mm; Standard component location; 430 l alu fuel tank LH, height 620 mm; Tank for AdBlue® 80 l, on left-hand mudguard; No front underrun protection; Catwalk with step; Rear mudguards; Spray suppression; Work lamp LED.

Optional

08740 Free space between front and rear axle	16157 Fuel tanks, material and sizes
07007 Component-free right hand side, 1500 mm	07071 Spare wheel carrier right-hand side
03598 Component-free right hand side, 1700 mm	03323 Rear light with LEDs
02883 Component-free right-hand side, 1900 mm	

DRAWBAR AND TRAILER EQUIPMENT

JOST JSK37C cast iron 150+40mm; No lead-up ramps; Pneumatic trailer connection C-type; Electric connection 24 V / 2x7 pins.

Optional

03178 Towing hook D= 4.3	16151 5th wheel makes and heights
---------------------------------	--

BODIES AND PREPARATIONS FOR BODYING

Optional

02811 Tail lift connection Anderson	02812 Tail lift connection REMA
--	--

POWER TAKE-OFF (PTO)

Optional

16148 PTO types and positions

24V POWER SUPPLY

Alternator 110 A, batteries 2x 175 Ah..

Optional

04492 Alternator 130 A	07671 Batteries 2x210Ah AGM C-type
08775 Alternator 150 A	
01257 Batteries 2x140Ah	06440 Batteries 2x230Ah

GVM AND GCM

Chassis weight related technical GVM max 20500 kg; Driveline related max GCM 44000 kg class 2.

APPLICATION CONDITIONS

Air intake front.

Optional

02260 Extra cab insulation	06614 Anti-dust blow-up shield
03648 Cyclonic air intake high	06620 Anti-dust blow-up shield + bugscreen

SERVICE AND MAINTENANCE

Standard Warranty takes care of 1 year complete vehicle as supplied by the OEM (excl. real wear parts), 2nd year driveline and 1st year breakdown.; ITS service.

Optional

08311 Service interval extended
--

VEHICLE DELIVERY

Minimum toolkit.

Optional

07569 Lifting jack

OPTION PACKAGES

Optional

17448 Safety pack	17625 Climate Pack
17595 Executive Pack XD/XF	

XFC 410

FT 4X2 Tractor

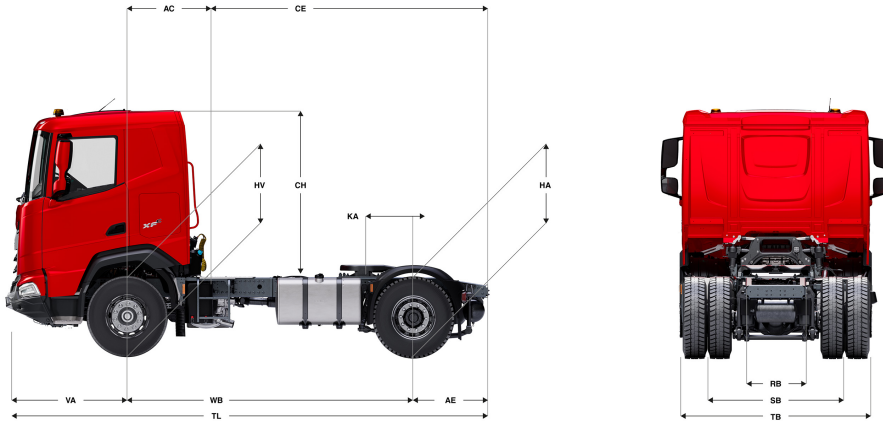

	Wheelbase - AE		Unladen weight ¹⁾			Gross Carrying Capacity			Variable dimensions								
	WB	AE ⁵⁾	Front	Rear	Total	Front	Rear	Total	AC	CE	CH	KA ⁶⁾	TL	HA ⁷⁾	HA ⁸⁾	TK ⁹⁾	TW ¹⁰⁾
DAY CAB	3,60	0,99	4975	2149	7123	3025	9351	10877	0,50	4,09	2,23	0,47	6,20	1,08	1,06	12,99	14,39
	3,80	0,99	4972	2163	7135	3028	9337	10865	0,50	4,29	2,23	0,67	6,40	1,08	1,06	13,50	14,92
	4,00	0,99	5031	2234	7265	2969	9266	10735	0,50	4,49	2,23	0,72	6,60	1,08	1,06	14,02	15,44
SLEEPER CAB	WB	AE ⁵⁾	Front	Rear	Total	Front	Rear	Total	AC	CE	CH	KA ⁶⁾	TL	HA ⁷⁾	HA ⁸⁾	TK ⁹⁾	TW ¹⁰⁾
	3,60	0,99	5111	2149	7259	2889	9351	10741	0,83	3,76	2,23	0,47	6,20	1,08	1,05	12,99	14,39
	3,80	0,99	5108	2163	7271	2892	9337	10729	0,83	3,96	2,23	0,67	6,40	1,08	1,05	13,50	14,92
SLEEPER HIGH CAB	WB	AE ⁵⁾	Front	Rear	Total	Front	Rear	Total	AC	CE	CH	KA ⁶⁾	TL	HA ⁷⁾	HA ⁸⁾	TK ⁹⁾	TW ¹⁰⁾
	3,60	0,99	5141	2149	7290	2859	9351	10710	0,83	3,76	2,71	0,47	6,20	1,08	1,05	12,99	14,39
	3,80	0,99	5138	2163	7302	2862	9337	10698	0,83	3,96	2,71	0,67	6,40	1,08	1,05	13,50	14,92
	4,00	0,99	5198	2233	7431	2802	9267	10569	0,83	4,16	2,71	0,72	6,60	1,08	1,06	14,02	15,44

OTHER DIMENSIONS	VA: 1,61	HV ¹¹⁾ : 1,14	HV ¹²⁾ : 1,05	RB: 0,79	SB: 1,82	TB ¹³⁾ : 2,48
------------------	----------	--------------------------	--------------------------	----------	----------	--------------------------

- 1) GVM in conformity with registration documents.
- 2) GCM in conformity with registration documents.
- 3) Axle load with standard tyre size.
- 4) Chassis and cab weight calculated with: Standard specification items only with 430 litres of fuel, 80 litres of AdBlue® and driver of 90 kg, tolerance ± 3%. Changing of the specification can have major impact on vehicle weight.
- 5) Other AE dimensions may be available for shown WB.
- 6) Calculate customer specific KA with TOPEC.

- 7) Unladen height at centre of driven axle(s).
- 8) Laden height at centre of driven axle(s).
- 9) TK = turning circle between kerbs.
- 10) TW = turning circle between walls.
- 11) Unladen height at centre of front axle(s).
- 12) Laden height at centre of front axle(s).
- 13) TB is overall width at rear. (At centre of front axle 255).

Depending on the vehicle configuration a specific option may not be possible. The availability and specification of this vehicle may differ per country. For further information please contact the DAF organisation. Pictures and technical illustrations are not binding in detail and can differ from the standard specification. Subject to modification without prior notice.