

Specification sheet

XG 450

FTP 6X2 Tractor



ENGINES

XG NewGen 450 MX-11 (330 kW / 449 hp)
XG NewGen 430 MX-13 (315 kW / 428 hp)
XG NewGen 480 MX-13 (355 kW / 483 hp)
XG NewGen 530 MX-13 (390 kW / 530 hp)

GVM¹⁾

23900 kg
Max. front 8000 kg
Max. rear 15900 kg

GCM²⁾

44000 kg

CAB EXTERIOR

Luxurious cab for XG series, with unrivalled aerodynamics for fuel efficient driving and low CO2 emissions. The huge and deep frontscreen, curved at the sides combined with large side windows offer an unsurpassed direct view for the driver, to enhance road safety. The cab interior is extremely comfortable for driving, living and sleeping with unprecedented spaciousness and practical layout. Cab length: 2690 mm; cab width: 2500 mm. Number of cab entrance steps: 3.; Cab suspension mechanical; LED head lights; Front view mirror.

Optional

02889 Chassis front execution: no bottom plate	01925 Two LED work lamps for cab rear wall
02952 Chassis front execution: bottom plate aero	01891 Hazard beacons on cab front, prepared
03358 External sun visor	06629 Two hazard beacon lights
06790 Aluminium ladder 1-piece	03232 Front windscreen with solar control foil
06791 Aluminium ladder 2-piece	
03922 Fog lights front	01550 No front view mirror
00949 LED Skylights; aux. LED lights on cab rf, prepared	01358 No DAF Digital Vision System
	01913 DAF Corner View

AERODYNAMICS

Optional

01567 Adj. roof air deflector; over 4 m (!) for XG cab	03074 Side collars, both sides hinged
04906 Side collars, one side hinged	

COLOURS

Cab colour E1980 Crystal White; Chassis colour grey.; Colour of bumper: Crystal White.

CAB INTERIOR

Cab interior trim colour: Exclusive; Dashboard finish: Plateau; Cab interior decoration: Hexagon; Driver seat: Comfort Air; Arm rest driver seat; Co-driver seat: cinema with fabric cover; Dashboard table; Storage compartment in centre; Luggage carrier; Automatic Temperature Control and airc; Auxiliary cab heater (water); No roof hatch.

Optional

02355 Steering wheel, leather	04069 Two refrigerators
02043 Dashboard finish: Vision	02854 Xtra Comfort mattress for lower bunk
02353 Cab interior decoration: Argenta	02841 Foam mattress for adjustable lower bunk
02350 Cab interior decoration: Natura	01775 Xtra Comfort mattress with topper for lower bunk
07733 Driver seat: Luxury Air	02858 Xtra Comfort mattress for adjustable lower bunk
07736 Driver seat: Super Air	02860 Xtra Comfort mattress + topper for adj. lower bunk
07737 Driver seat: Xtra Leather Air	02380 Mattress for DAF Relax Bed
02241 Driver seat, swivel base	04150 Mattress with topper for DAF Relax Bed
06469 Storage compartment with drawer in centre	01066 Upper bunk
04070 Two drawers	06970 Automatic Cab Climate Control
04050 Refrigerator and drawer	01967 Park air conditioning, integrated

COMMUNICATION AND DRIVING MANAGEMENT

PACCAR Connect; Tachograph digital, Stoneridge version G2V2A; Speed limiter setting 85/90 km/h; Adaptive Cruise Control with FCW and AEBS-3; Driver Performance Assistant.

Optional

09681 Preparation for Maut	03684 Infotainment including DAF Truck Navigation
03470 Infotainment incl. DAF Truck Nav. and tablet prep.	

SAFETY AND SECURITY

DAF drowsiness detection; Lane Departure Warning System; Vehicle Stability Control (VSC); Basic engine immobiliser system.

Optional

08631 Air bag (driver) and 2 seat belt tensioners	03628 DAF drowsiness & distraction detection
02178 Main switch with second control in the cab	00795 Safety regulations EC ADR
02569 No Driver State Monitoring	01952 No DAF Side/Turn Assist

SUSPENSION AND AXLES

Front: 8.00 t, parabolic, 163N; Non-steered leading axle.; Rear axle load 12.00 t; Rear: 16.60 t, air suspension, SR1344; Lifting device.

Optional

01769 Front axle load 7.50 t	04588 Rear axle SR1347
06257 Front axle load 9.00 t	08191 Axle load monitoring
04647 Front springs air	

WHEELS AND TYRES

Driven rear axle(s): 315/70R22.5; F1,315/70R22.5GO EQMSU 158/150 L Steering ABA 3P; R1,315/70R22.5GO EQMDU 154/150 L Traction ABB 3P.

Optional

16152 Tyre makes and types

DRIVELINE

Engine MX-11, multi torque 6 cylinder diesel engine, 10.8 litres. Output 330 kW (449 hp) at 1600 rpm. Maximum torque 2350 Nm at 900-1125 rpm.; Exhaust emission Euro 6; Eco fuel; 12-speed TraXon 12TX2210 DD, 16.69-1.00; Gearbox ratio 16.69-1.00; Rear axle ratio 2.38; ASR.

Optional

07110 Eco performance	08371 Long Combination Vehicle (LCV)
07101 Standard transport, Lite version	09638 Off-road applications
09636 Heavy haulage	01498 Off-road applications with Rock-free function
09637 Liquid transport	02843 Mechanical differential lock

BRAKE SYSTEM

MX Engine Brake; Ventilated disc brakes front and rear. Dual circuit air system with electronic control (EBS). Engine driven, water cooled aire compressor with automatic air heated dryer..

Optional

02287 Exhaust brake	01572 Park brake control electro-pneumatic
02281 ZF Intarder	
02304 MX Engine Brake and ZF Intarder	01497 Park brake control pneumatic with spoken warning
02715 ZF Intarder	04901 Spring brake cylinders on the first front axle

CHASSIS

Wheelbase 4.05 m / rear overhang 0.99 m; Side member height 260 mm; Standard component location; 510 l alu fuel tank with step LH, height 620 mm; Tank for AdBlue® 85 l, on left-hand mudguard; Front underrun protection (FUP); Catwalk with step; Rear mudguards; Spray suppression; Work lamp LED.

Optional

16157 Fuel tanks, material and sizes	03323 Rear light with LEDs
--------------------------------------	----------------------------

DRAWBAR AND TRAILER EQUIPMENT

JOST JSK36DV pressed steel 205+40mm; Lead-up ramps; Pneumatic trailer connection C-type; Electric connection 24 V / 2x7 pins.

Optional

16151 5th wheel makes and heights

BODIES AND PREPARATIONS FOR BODYING

Optional

02811 Tail lift connection Anderson	02812 Tail lift connection REMA
-------------------------------------	---------------------------------

POWER TAKE-OFF (PTO)

Optional

16148 PTO types and positions

24V POWER SUPPLY

Alternator 110 A, batteries 2x 230 Ah..

Optional

04492 Alternator 130 A	07671 Batteries 2x210Ah AGM C-type
08775 Alternator 150 A	

GVM AND GCM

Chassis weight related technical GVM max 23900 kg; Driveline related max GCM 44000 kg class 2.

APPLICATION CONDITIONS

Air intake front.

Optional

08400 Silent mode	06614 Anti-dust blow-up shield
02260 Extra cab insulation	06620 Anti-dust blow-up shield + bugscreen

SERVICE AND MAINTENANCE

Standard Warranty takes care of 1 year complete vehicle as supplied by the OEM (excl. real wear parts), 2nd year driveline and 1st year breakdown.; ITS service.

Optional

08311 Service interval extended

VEHICLE DELIVERY

Minimum toolkit.

Optional

07569 Lifting jack

OPTION PACKAGES

Optional

17448 Safety pack	17625 Climate Pack
17596 Executive Pack XG/XG+	

Go to [DAF.com](https://www.daf.com) to configure your own perfect DAF.

XG 450

FTP 6X2 Tractor

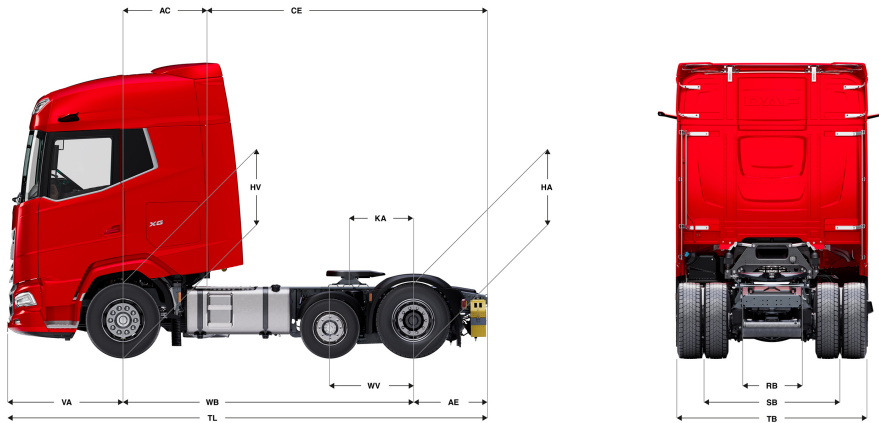

XG CAB	Wheelbase - AE		Unladen weight ¹⁾			Gross Carrying Capacity			Variable dimensions								
	WB	AE ⁵⁾	Front	Rear	Total	Front	Rear	Total	AC	CE	CH	KA ⁶⁾	TL	HA ⁷⁾	HA ⁸⁾	TK ⁹⁾	TW ¹⁰⁾
	4,05	0,99	5113	3052	8165	2887	12848	15735	1,16	3,88	2,96	0,67	6,57	0,97	0,94	13,36	14,74

OTHER DIMENSIONS VA: 1,53 WV: 1,10 HV¹¹⁾: 0,97 HV¹²⁾: 0,90 RB: 0,79 SB: 1,82 TB¹³⁾: 2,48

1) GVM in conformity with registration documents.
 2) GCM in conformity with registration documents.
 3) Axle load with standard tyre size.
 4) Chassis and cab weight calculated with: Standard specification items only with 510 litres of fuel, 85 litres of AdBlue® and driver of 90 kg, tolerance ± 3%. Changing of the specification can have major impact on vehicle weight.
 5) Other AE dimensions may be available for shown WB.
 6) Calculate customer specific KA with TOPEC.

7) Unladen height at centre of driven axle(s).
 8) Laden height at centre of driven axle(s).
 9) TK = turning circle between kerbs.
 10) TW = turning circle between walls.
 11) Unladen height at centre of front axle(s).
 12) Laden height at centre of front axle(s).
 13) TB is overall width at rear. (At centre of front axle 255).

Depending on the vehicle configuration a specific option may not be possible. The availability and specification of this vehicle may differ per country. For further information please contact the DAF organisation. Pictures and technical illustrations are not binding in detail and can differ from the standard specification. Subject to modification without prior notice.